

μ TP-5820A
 μ TP-5824A

INSTRUCTION MANUAL

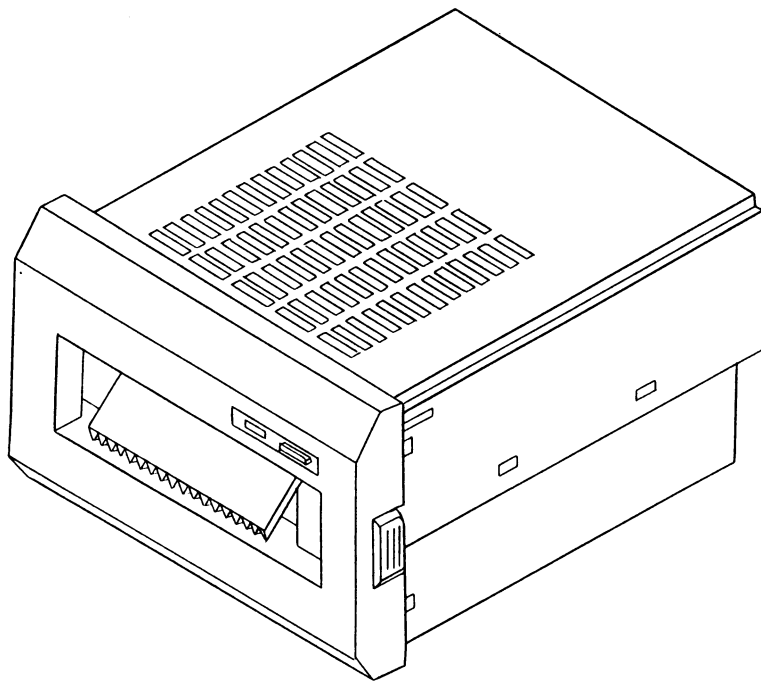

Before using the printer you must read this instruction manual well for proper operation. Be sure to save this manual and keep it at hand.

 **SANEI ELECTRIC INC.**

Precautions on Handling the Printer

When incorporating our product in another system or unit, the system must be so designed so that the customer's final product and system are not defective due to any faults caused by our product and the corresponding delivery must be performed.

When incorporating our product in another system or unit, please consult with our sales office.

We shall not assume any responsibility with respect to damage and loss occurring due to use of the product without our consultation.

If a fault occurs for any reason, please be aware that the product shall basically be replaced up to a limit such that the extent of replacement does not exceed the product value or its equivalent.

In addition, we shall confirm the faults and then take swift action when replacing the product in question.

Contents

Before Use	1
Parts Designation	3
Features	3
How to Use	4
1. Preparation.....	4
1-1. Unpacking.....	4
1-2. Part functions.....	4
1-3. Outer dimensions.....	5
2. Setting roll paper.....	6
3. Functions.....	8
3-1. Test printing.....	8
3-2. Printing mode.....	8
3-2-1. Front view.....	8
3-2-2. Setting correct standing printing and reversed standing printing.....	9
3-3. Control codes.....	9
3-4. Character font configuration.....	12
4. Data code table.....	13
Maintenance	14
Specifications	15
1. General specifications.....	15
1-1. Printer specifications.....	15
1-2. Operating conditions.....	15
2. Interface specifications.....	17
2-1. I/O connection terminals.....	17
2-2. Input/output functions.....	18
2-3. Basic operations.....	19
2-4. Data timing.....	19
2-5. Electric conditions.....	19
Options	20

Before use

CAUTION (Observe precautions for safe use)

Just after printing, the printer motor becomes hot and dangerous. Do not touch it directly.

Set the operating power supply to $5Vdc \pm 5\%$. An extremely high current flow may cause a fire.

Precautions on Use

- Use the specified DC power supply (+5Vdc 3A).
An extremely high or low voltage may cause a malfunction. Take care not to mix excessive noise in the power line. When wiring the power line, fully consider the line impedance.
- Printing with no sheet loaded may cause a malfunction. Avoid such unloaded printing.
- Do not drop or bump the printer.
- Absolutely avoid disassembling or repairing the printer yourself.
- Do not moisten the printer with water.
- When using the printer, do not remove the panel.
- Pulling a printing sheet from the insertion slot in the reverse direction may cause a malfunction.
- If an abnormality is found in the printer (when a strange sound or odor is issued), immediately turn off the power supply. Determine whether or not the abnormality remains and consult with the shop where you purchased the product or us.

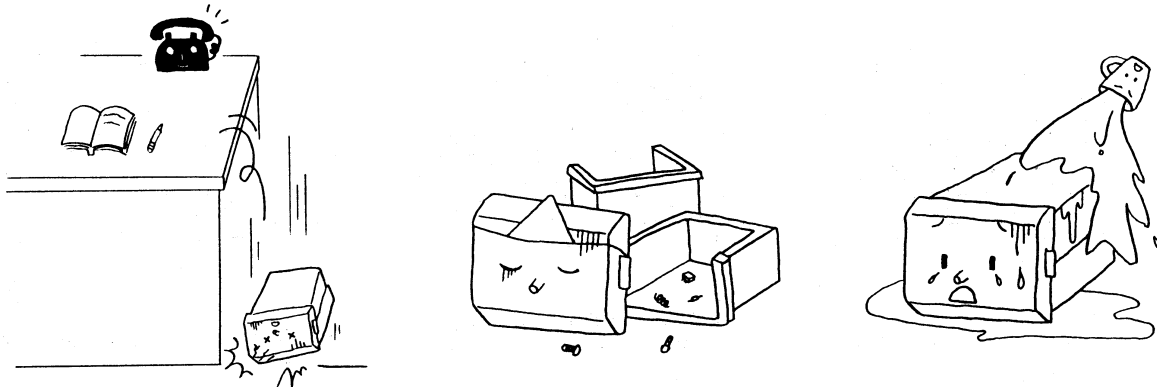

Precautions on Handling Thermal-Sensitive Paper

The thermal-sensitive paper has been specially treated with a chemical agent and is colored by thermal chemical reaction. Fully heed the following:

- Store paper in a dry, cool, or dark place.
- Do not scrub paper hard with a solid substance.
- Do not place it near an organic solvent.
- Do not leave paper in contact with PVC film, an eraser, or adhesive tape for a long period of time.
- Do not overlap it with diazo paper or wet copy paper just after copying.
- When gluing paper, do not use chemical paste.
- Adhesive tape may discolor thermal-sensitive paper. Use double-faced tape to join the rear surfaces.
- Touching paper with a sweaty hand causes your fingerprint to be marked on the paper or the record to become blurred.
- When using paper as a receipt for a customer, clarify that it is thermal-sensitive paper and print the precautions for storage on the sheet.
- Use specified thermal-sensitive paper.

Location

- Use your printer in a horizontal to vertical place.

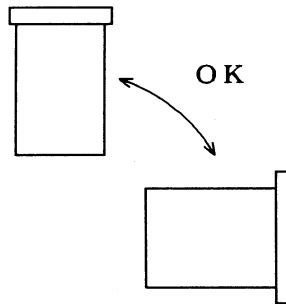

- Using or storing your printer in the following places may cause a malfunction.

Avoid dusty places or a places with excessive particulates.

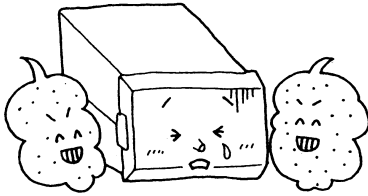

Avoid places subjected to strong vibration.

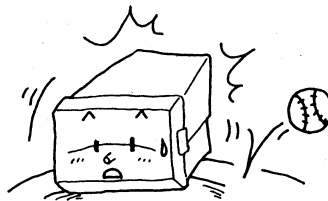

Avoid places where electromagnetic noise or corrosive gas is generated.

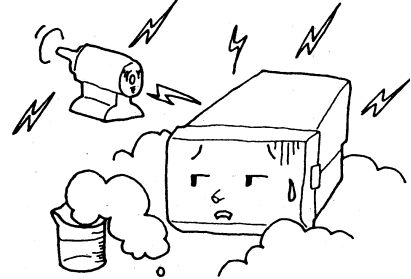

Avoid places whose temperature is 40°C or higher.

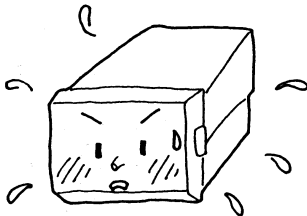

Avoid places whose temperature is below 0°C

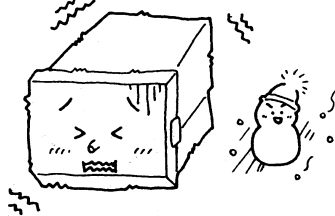

Avoid places subjected to direct sunlight.

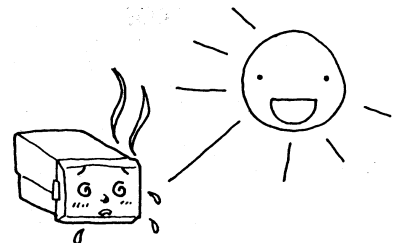

Avoid places with much water or oil. particulates.

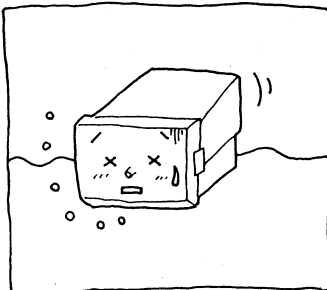

Avoid places where the relative humidity is 80% or greater.

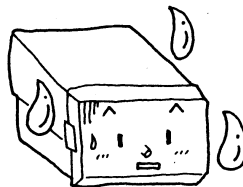

Avoid places subject to abrupt temperature changes and where condensation can occur.

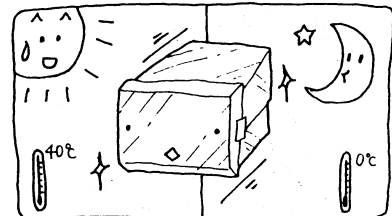

- When using your printer in a very dusty location, attach the dust-proof cover to the printer, locate an air ventilation hole in the system you incorporate the printer in, and take other measures against dust.

Parts Designation

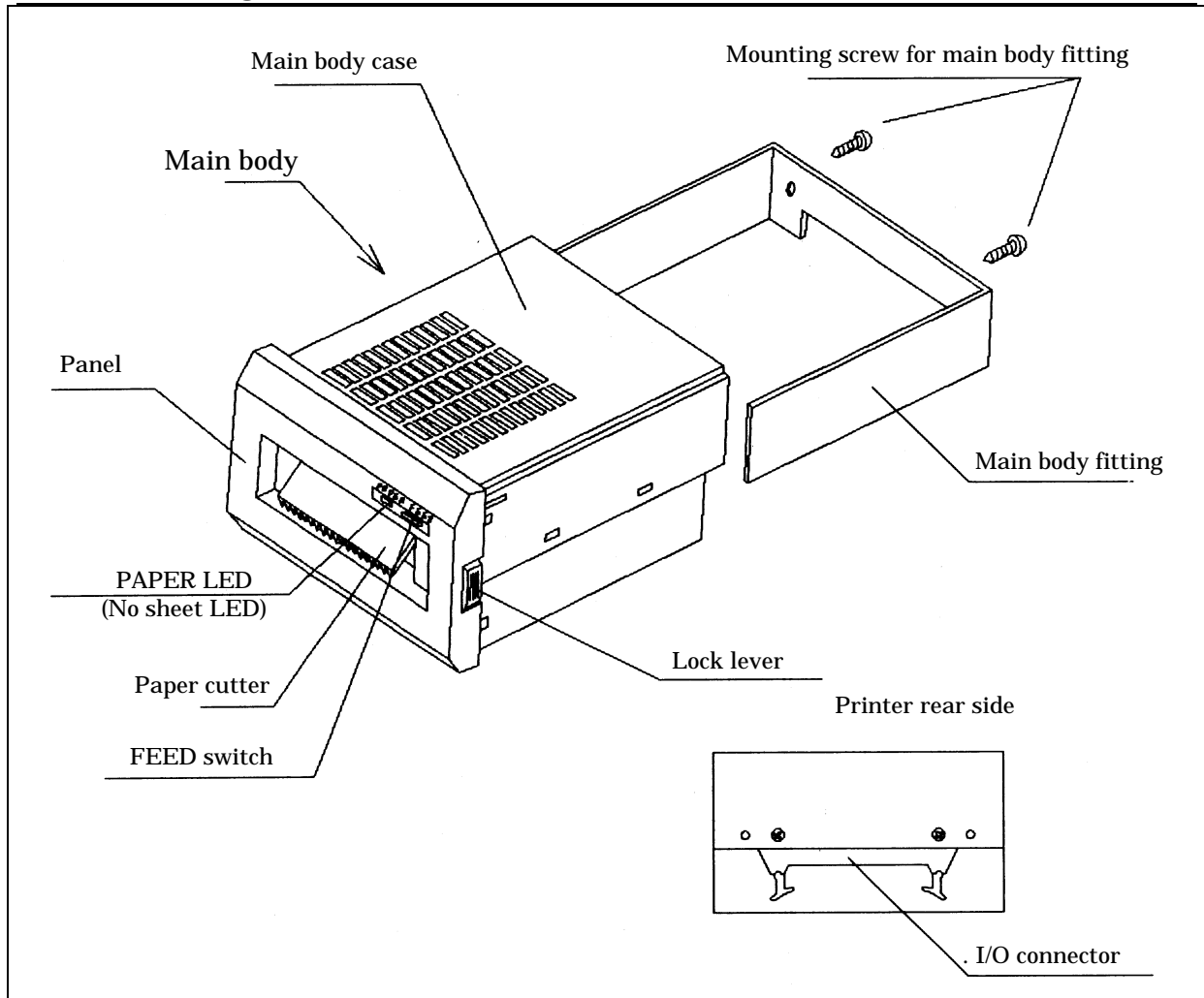

Features:

uTP-5820A/24A incorporates data memory and a character generator. It is an ultra-small thermal printer that prints data input from a computer or the other host systems via a thermal-sensitive printing method.

It has the following features:

Design/ mechanism

The printer is contained in a compact case and can be mounted in a horizontal to vertical location. It needs little space for mounting owing to its small size and one-touch operation.

Printing

The thermal-sensitive printing method eliminates the need for consideration of the surroundings and issues almost no noise during operation.

The character size is 7 x 5 in and they are clear.

Functions and Power supply

The printer enables positionally correct or reversed printing as well as double-sized printing. It stores roll paper inside the main body. It is available with a no-sheet sensor.





It allows test printing. The operating voltage is +5Vdc \pm 5%. It applies no-load with the system with low power consumption. Further, it is highly reliable because it is available with a power protection circuit.

How to Use

1. Preparation

1-1. Unpacking

After unpacking the product, ensure that the main body and accessories are all found.

 Main body (μ TP-5820A or 24A)	1
 Main body fitting	1
 Main body fitting mounting screw	2
 Thermal-sensitive paper (incorporated in the main body, P-58-15)	1 volume
 Instruction Manual	1 volume

 A variety of thermal-sensitive paper is available from us.

1-2 Part functions

- FEED switch
Pressing this switch consecutively feeds paper while it is pressed.
* Turning on the power with the switch pressed performs test printing.
- PAPER LED
Paper end (PE) LED that goes on when no roll paper is found.
- Sheet cutter
Used for cutting roll paper
* Paper can be cut by slightly lifting roll paper up and pulling it.

1-3. Outer dimensions

Unit: mm

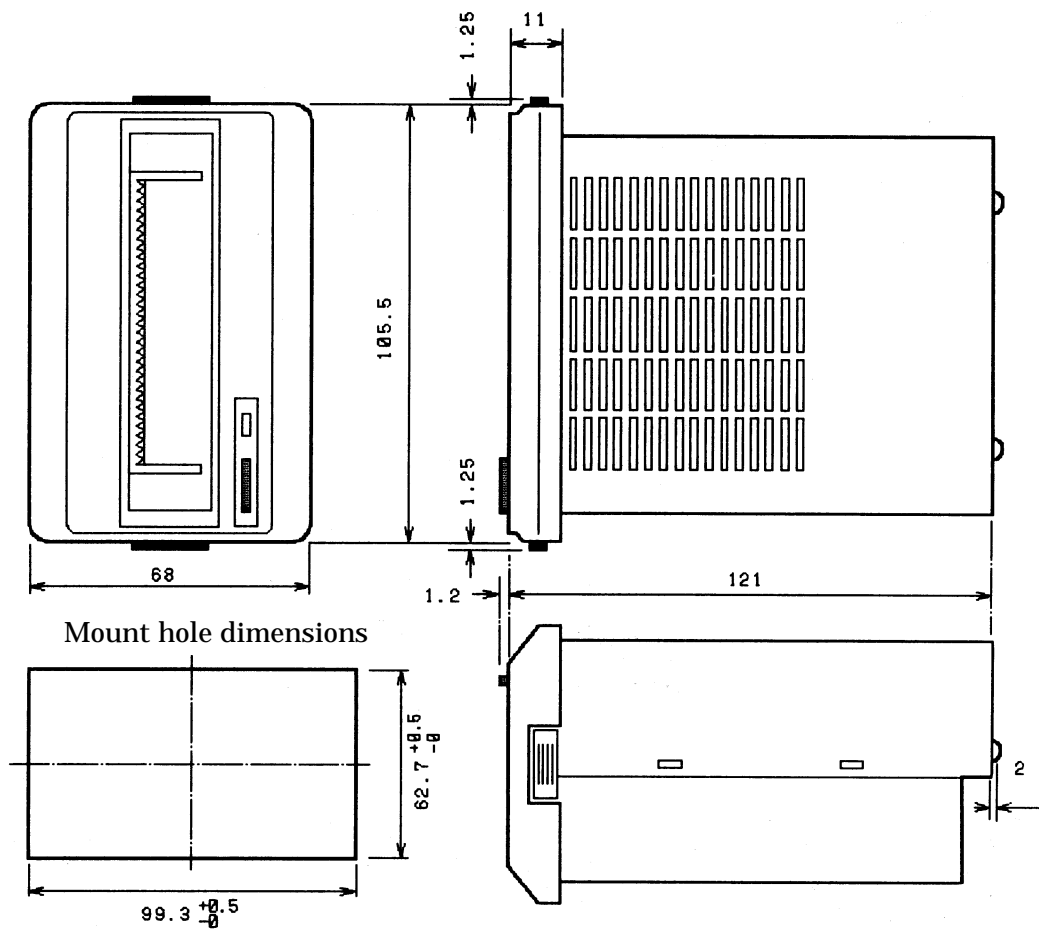

- Main body fitting

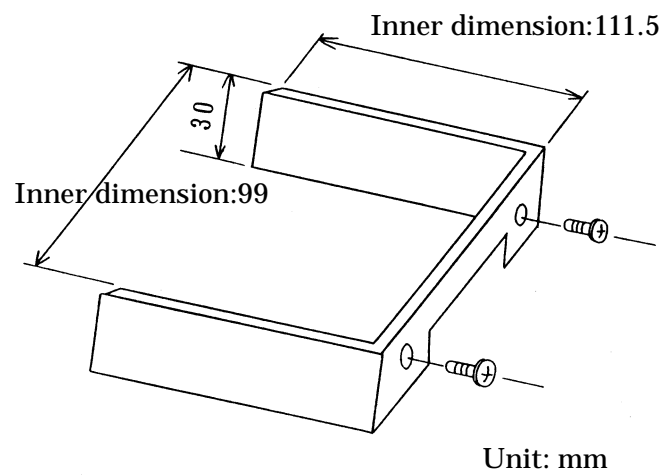

2. Setting roll paper

Roll paper can be set inside the main body. Pull the main body out from the front surface and set roll paper.



Caution

When setting roll paper with the power ON, be sure to use the pull-out knob to draw the board. Because a small amount of current is flowing in it, do not touch the board directly.

- (1) While pushing the lock levers on both sides of the panel, remove the panel.

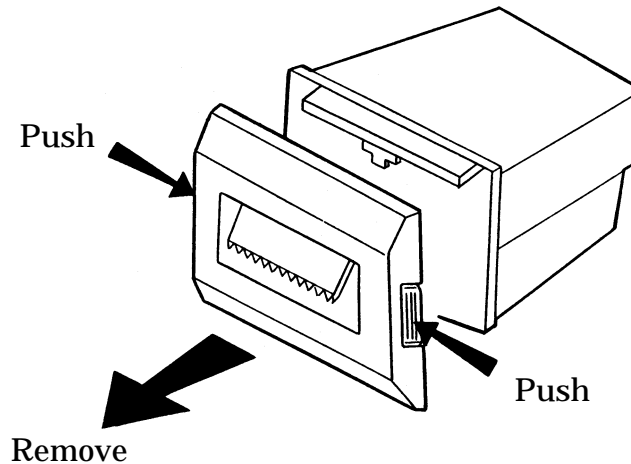

- (2) Use the pull-out knob to draw the body inside the printer, and set roll paper onto the roll paper fixing shaft. (Horizontally cut the tip of roll paper as shown in Figure 1.)

Note: The pasted section of roll paper does not accept printing, so cut roll paper for the corresponding section without the pasted section.

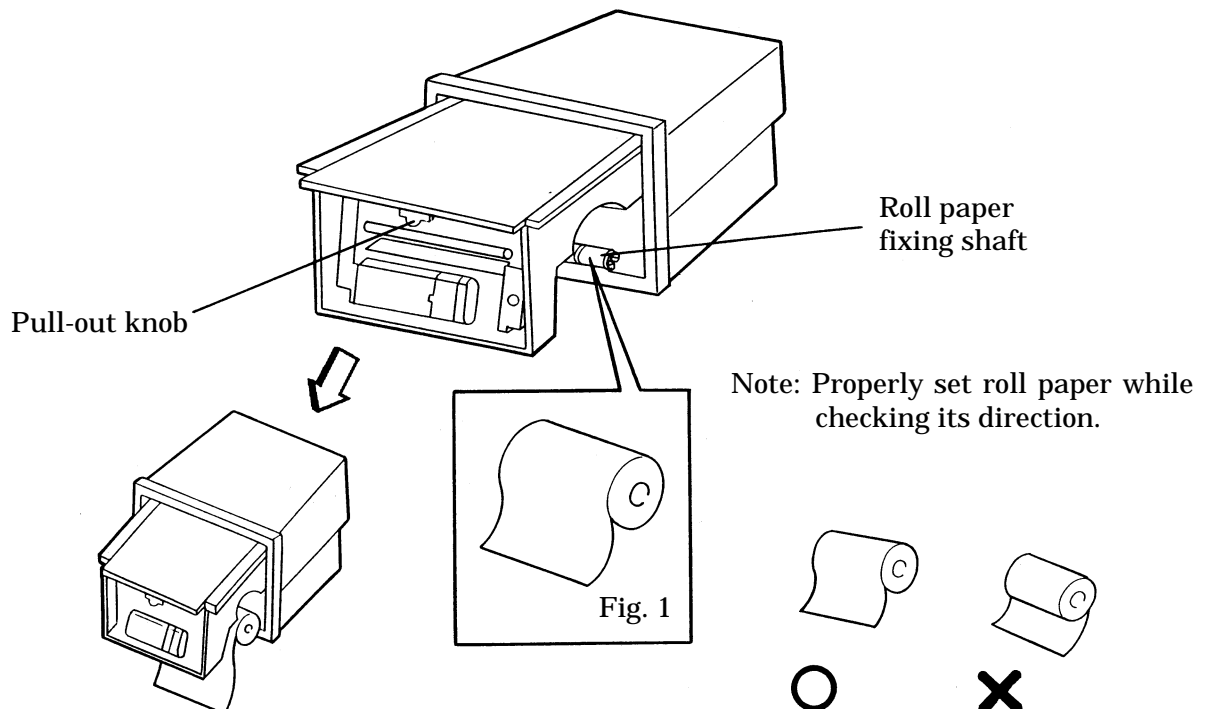

(3) Pull out roll paper to this side and turn on the power supply. While pressing the FEED switch, insert the tip of roll paper with it straight so that it can be set horizontally with the wall surface of the sheet insertion slot.

Note: If paper is bent, it may cause jams.

If roll paper is not engaged with the roller, no paper is fed. Insert paper deep enough to reach the roller.

Continuously press the FEED switch until roll paper comes out from the printer head section.

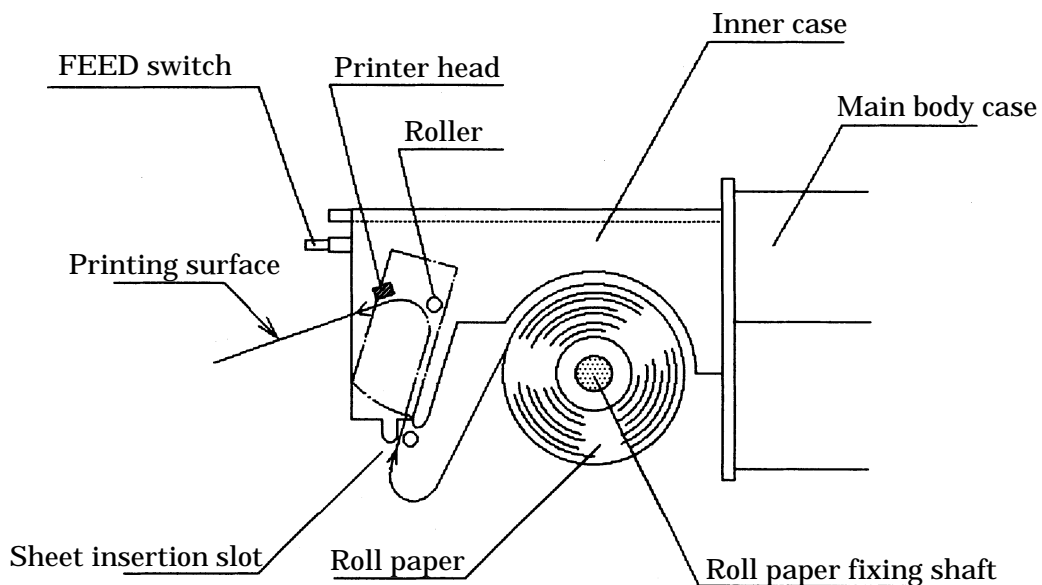

(4) Place the tip of roll paper that has come out on the outer side of the sheet cutting outlet of the panel and set the inner case and panel in the case.

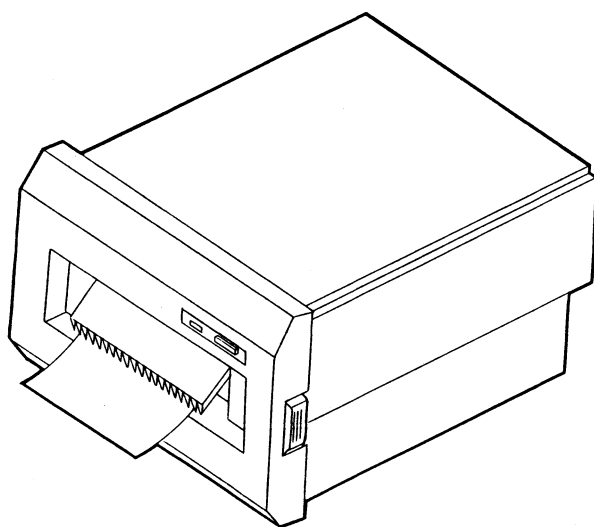

3. Functions

3-1. Test printing

Turning on the power with the FEED switch pressed will result in test printing beginning after feeding paper by one line without printing. All characters are printed once, and then 10 lines of a zigzag pattern (0FEH) patterns are printed.

Test printing sample

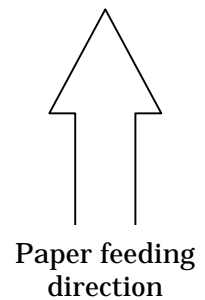
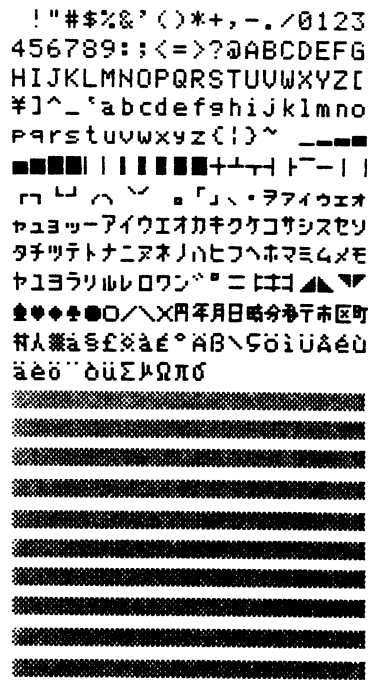

μ TP-5820A (Correct standing printing)

Note: The correct and reverse standing printing switch can be used for test printing in a positionally reversed position.

3-2. Printing mode

3-2-1. Front view (When the panel is removed)

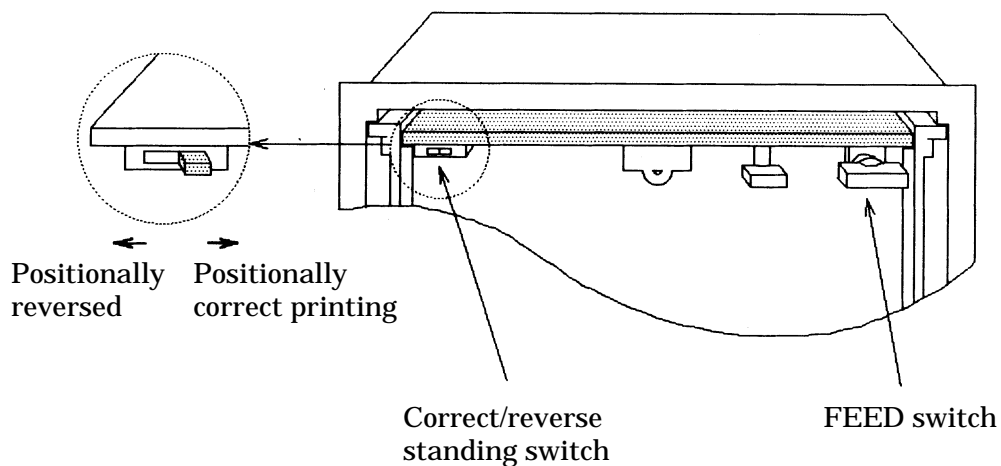

3-2-2 Setting correct standing printing and reversed standing printing

After turning power ON during initialization, the printer checks the correct and reverse standing printing switch on the left side of the circuit board to set correct or reversed standing printing.

Note: When changing the setting, enter the reset or turn OFF the power supply once.

Neglecting to do this does not change the setting even by changing the switch.

Correct standing printingCorrect/Reversed standing printing switch Correct
(Right side towards you)

Reversed standing printingCorrect/Reversed standing printing switch Reversed
(Left side towards you)

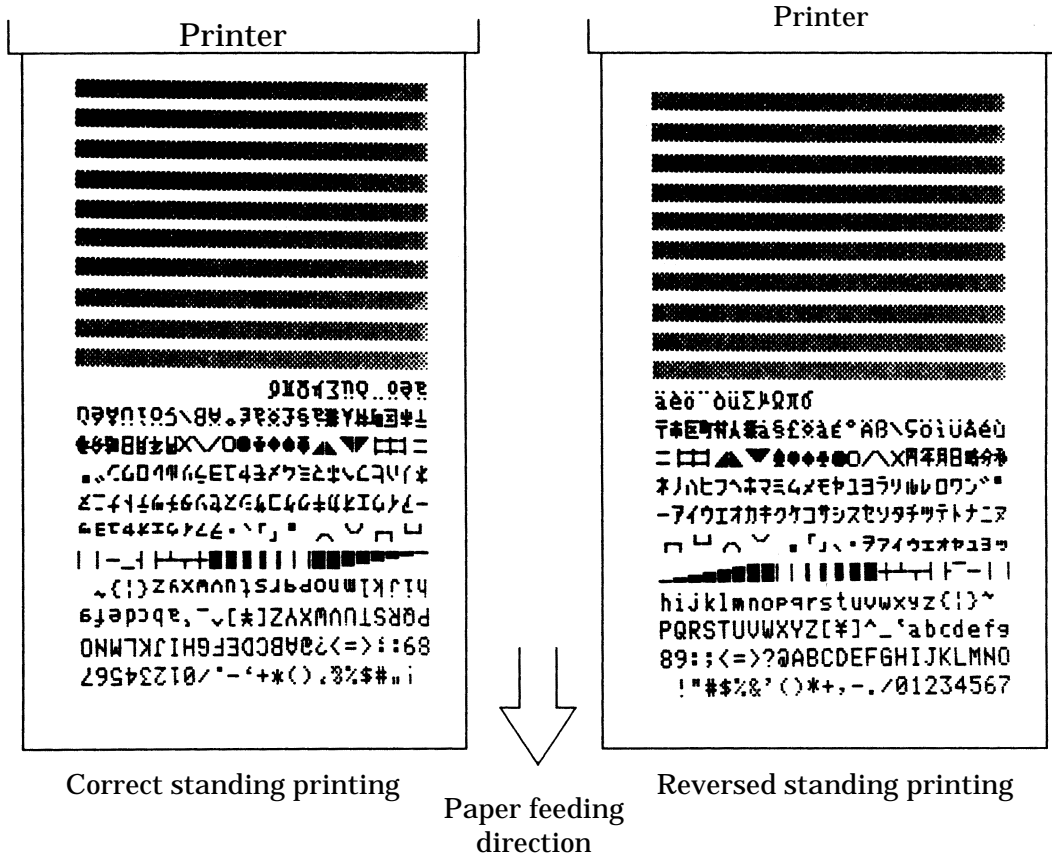

3.3 Control codes

The μ TP-58 series provides the following control commands.

Function code	Name	Hexadecimal code	Decimal code	Reference page
LF	Line feed	<0A>	<10>	10
CR	Carriage return	<0D>	<13>	10
SO	Double-size enlarged printing mode specification	<0E>	<14>	10
SI	Double-size enlarged mode reset	<0F>	<15>	10
CAN	Cancel	<18>	<24>	10
ESC+"S"+n1+n2+n3+n4	Bit-image graphic	<1B><53>	<27><83>	11
ESC+"c"	Special character specification	<1B><63>	<27><99>	12
ESC+"R"+n	International character specification	<1B><52>	<27><82>	12

LF

[Name] Printing-paper feeding
[Code]: <0A> H or <10>D
[Function]: Prints data in the printer buffer and feeds paper.
[Operation]: When no data is found in the printer buffer, paper is fed only.

CR

[Name] Printing/paper feeding
[Code] <0D>H or <13>D
[Function] Prints data in the printer buffer and feeds paper.
[Operation] When data preceding <CR> is not found, nothing is done,
When data + <CR> + <LF>, prints data + <CR>, and <LF> is ignored.

SO

[Name] Double-size enlarged printing mode specification
[Code] <0E>H or <14>D
[Function] With the code entered, data is printed in double-size enlarged characters.

SI

[Name] Double-size enlarged printing mode reset
[Code] <0F>H or <15>D
[Function] Resets the double-size enlarged printing mode by entering the code.
[Example of coding]

```
Lprint chr$(14);" ABC"; chr$(15);" DEF";chr$(13)
```

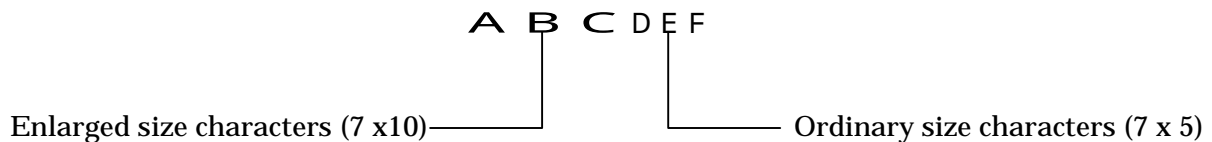

CAN

[Name] Cancel
[Code] <18>H or <24>D
[Function] Clears all the data stored in the data buffer and waits for the next data entry.
[Operation] When SO, SI, ESC+"S" + n1n2n3n4 has been entered in the data buffer, the function is cleared. However, ESC +"c", ESC +"R" + n performs a flag operation when this command is entered, it is not entered in the data buffer, so that the previous state is not resumed even when a CAN code has been entered.

ESC + "S" + n1 + n2 + n3 + n4 + DATA

- [Name] Bit image mode (Graphic mode)
- [Code] <1B>H + <53>H + n1 + n2 + n3 + n4 + DATA or <27>D + <83>D + n1 + n2 + n3 + n4 + DATA
- [Function] Ordinarily, character printing is performed, but by receiving specific control codes and data according to the stipulated procedure, bit-image graphic operation and operation in which characters and bit-image graphics are mixed are possible.
- [Operation] How to control the soft graphic mode is to use the [ESC(1BH) + "S" (53H)] and a 4-digit figure following it to declare the bit image graphic length beforehand. After data printing, the original state is resumed.

Note: The inter-line space exists.

ESC + "S" + n1 + n2 + n3 + n4 + graphic data

Example: When feeding 192 bit image data items

1BH, 53H, 30H, 31H, 39H, 32H, -----
192 data items

n1 + n2 + n3 + n4 is always a 4-digit integer. When data not conforming to the format has been entered, the instruction is not executed and processing stays as is.

Example:

Good		Bad	
0012		00AB	Data is not an integer.
0007		024	Data is not a 4-digit figure.

The relationship between the graphic data bit and printer head dot is as shown below. An example of the sof graphic mode is as shown below.

Example: 41H(A), 42H(B), 1BH(ESC), 53H(S), 30H(0), 30H(0)
30H(0), 33H(3), 41H(A), 42H(B), 43H(C), 43H(C)

: Printing is not performed because it is an unassigned dot.
(Data) (Dot)

- D0 - Unassigned
- D1 - First dot
- D2 - Second dot
- D3 - Third dot
- D4 - Forth dot
- D5 - Fifth dot
- D6 - Sixth dot
- D7 - Seventh dot



(Graphic section)

In the soft graphic mode, data overflow from a line is printed on the next line.

When a character code other than "S" is entered or a format of n1 to n4 is incorrect, the instruction is invalid, and the graphic data following it is printed as a character code.

ESC + "c"

[Name] Special character specification

[Code] <1B>H + <634>H or <27>D + <99>D

[Function] F9H to FDH in the character code table are changed as shown in the table below.

[Operation] This is a toggle operation. Executing ESC + "c" again resumes the original state. However, this change is performed every one line. In one line, "市" and " ", or "区" and " μ ", etc. cannot be used. It is not influenced by the CAN code.

When a character code other than "c" is entered, the instruction is invalid, and data is printed as is.

Code	H9H	FAH	FBH	FCH	FDH
Character at initial time	市	区	町	村	人
ESC + "c"		μ			

ESC+"R"+n

[Name] International character specification

[Code] <1B>H + <52>H + n or <27>D + <82>D + n

[Function] The international character set is changed. Part of the character code table is changed with set country characters.

[Operation] Once it is changed, the state is retained until the next command to be changed is entered. It is also not influenced by the CAN code.

Upon initialization, the character set is JAPAN.

When a character code other than "R" or a numeric value other than n=0H to 6H is entered, the instruction is invalid. Data is printed in international characters as set previously.

Country name	n	Country name	N	Country name	n	Country name	n
JAPAN	0	GERMANY	2	SWEDEN	4	U.S.A	6
FRANCE	1	U.K.	3	ITALY	5		

HEX	23H	24H	40H	5BH	5CH	5DH	5EH	60H	7BH	7CH	7DH	7EH
JAPAN	#	\$	@	[#]	^	'	<		>	~
FRANCE	#	\$	ã	°	ç	è	é	ê	ë	ù	ú	û
GERMANY	#	\$	è	ä	ö	ü	^	'	<		>	~
U.K.	£	\$	@	[\]	^	'	<		>	~
SWEDEN	#	×	é	ä	ö	å	ü	é	ä	ö	å	ü
ITALY	#	\$	@	°	\	é	è	ù	à	ò	é	ì
U.S.A.	#	\$	@	[\]	^	'	<		>	~

3-4 Character font configuration

The character font is configured as 8 x 6 dots as one unit.

(1) Ordinary character

Almost all of the character patterns are made of 7 x 5. The illegible character pattern is 7 x 6.

(2) Double-size enlarged character

The double-size enlarged character is printed by printing a character pattern twice.

4. Data code table (An undefined code is ignored.)

Character code table

High-order bit Low-order bit	0	1	2	3	4	5	6	7	8	9	A	B	C	D	E	F
0000		0001	SP	0	@	P	‘	p	—	十	SP	一	タ	ニ	1110	1111
0001		!	!	1	A	Q	a	q	—	丁	。	ア	チ	ム	上	円
0010		”	”	2	B	R	b	r	■	十	「	イ	ツ	メ	十	年
0011		#	#	3	C	S	c	s	■	十	」	ウ	テ	モ	十	月
0100		\$	\$	4	D	T	d	t	■	—	、	エ	ト	ヤ	▲	日
0101		%	%	5	E	U	e	u	■	—	・	オ	ナ	ユ	▲	時
0110		&	&	6	F	V	f	v	■		ヲ	カ	ニ	ヨ	▲	分
0111		,	,	7	G	W	g	w	■		ヲ	キ	ヌ	ラ	▲	秒
1000		((8	H	X	h	x		┌	イ	ク	ネ	リ	♠	十
1001))	9	I	Y	i	y		└	ウ	ケ	ノ	ル	♥	市
1010	LF	*	*	:	J	Z	j	z	■	┌	エ	コ	ハ	レ	◆	区
1011	ESC	+	+	:	K	[k	{	■	└	オ	サ	ヒ	ロ	♣	町
1100		,	,	<	L	¥	l		■	┌	ヤ	シ	フ	ワ	●	村
1101	CR	-	=	=	M]	m	}	■	└	エ	ス	へ	ン	○	人
1110	SO	.	>	>	N	^	n	~	■	┌	ヨ	セ	ホ	、	／	■
1111	SI	/	?	?	O	_	o	SP	+	└	ッ	ソ	マ	。	／	

The character inside the parentheses denotes a control code.

Maintenance

CAUTION 

When holding the printer, take the fullest care while handling it.

When the printer surface is contaminated, wipe off the contaminant with a dry soft cloth. If the contamination is severe, immerse a soft cloth in water containing a small amount of a neutral detergent. Wring the water out of the cloth well and wipe the printer surface with it. Then, wipe the surface with a dry cloth.

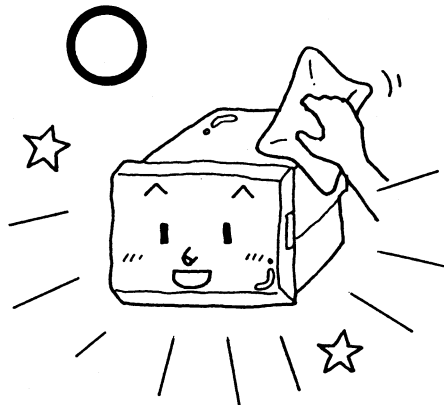

×

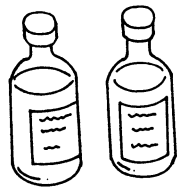

×

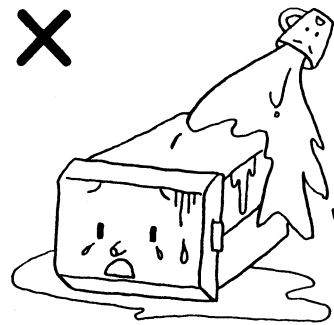

Cautions:

- Do not use a volatile chemical agent such as thinner, benzene, etc.
- Never moisten the internals of the printer with water, etc.

Specifications

1. General specifications

1-1. Printer specifications

Printing method:	Thermal-sensitive serial dot printing
Type of character:	Conforms to JIS-C6220, extended ASCII version (available with katakana), alphabetic characters (uppercase, lowercase), numeric figures, kana, symbols, and the like for 250 types in total
Character configuration:	7 x 5 dot matrix
Input character code:	JIS 8-bit code (See the code table.)
Data input method:	Conforming to Centronics standards. (Refer to the data timing).
Printing direction:	Left -> right with regard to the paper feeding direction.
Service life:	500,000 lines
Weight:	About 490 g (including the roll paper and the main body fitting).

Model name	Character dimensions (in mm)	Number of character digits (digits/line)	Printing speed (lines/sec.)
μ TP-5820A	2.4 × 1.5	20 2-dot space	About 0.8
μ TP-5824A	2.4 × 1.3	24 2-dot space	About 0.8

1-2. Operating conditions

Operating voltage:	+ 5Vdc ± 5%
Power consumption:	At operation: No more than 3.0A (instantaneous maximum value during printing) At wait: About No more than about 50 mA
Working temperature:	0 to + 50
Storage temperature:	-40 to + 60
Allowable humidity:	40 85%

About the power supply:

The μ TP power supply standards are as specified above. Consider an instantaneous maximum current of 3.0A during printing. (+5V-VP, Vcc, GND• four lines)

When sharing the power supply with the host system, take measures to avoid possible system problems due to instantaneous voltage drop (A significant transient voltage drop can be estimated).

- POWER ON conditions of the internal circuit

With power ON, the voltage level is detected and the circuit is initially reset under the following conditions:

* Time cycle

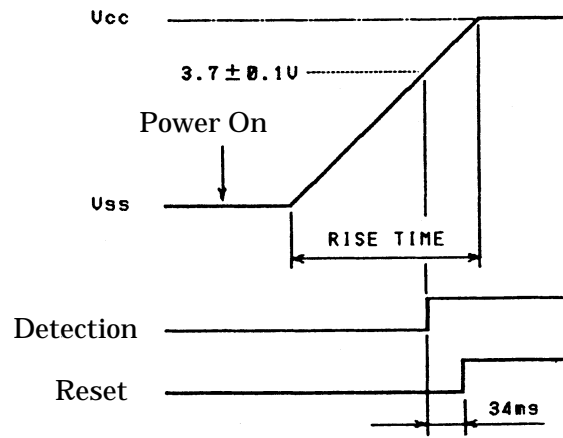

- Resetting conditions with POWER DOWN during operation

If power voltage fluctuation arises as follows, the circuit is reset like with POWER ON RESET:

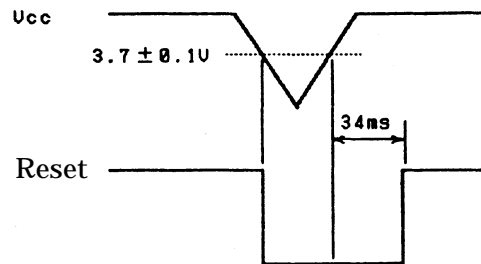

2. Interface Specifications

2-1. I/O connection terminals

- Connector plug 4234-0001LCSC (manufactured by 3M)
- I/O connector signal layout

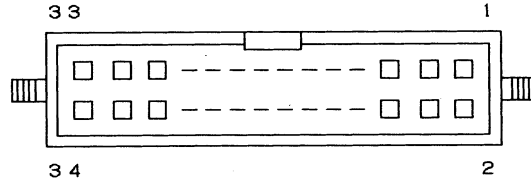

(Signal name is Active Low)

Terminal No.	Name	Direction	Description	Terminal No.	Name
1	$\overline{\text{STROBE}}$	Input	With the fall of the command signal for reading data, data is latched. The pulse amplitude must be 0.5 μ s or higher.	2	Return GND
3	DATA 0	Input	8-bit parallel data signal. When the data is 1, "HIGH". When 0, "LOW".	4	Return GND
5	DATA 1	Input		6	Return GND
7	DATA 2	Input		8	Return GND
9	DATA 3	Input		10	Return GND
11	DATA 4	Input		12	Return GND
13	DATA 5	Input		14	Return GND
15	DATA 6	Input		16	Return GND
17	DATA 7	Input		18	Return GND
19	$\overline{\text{ACK}}$	Output	Data input end signal	20	NC
21	BUSY	Output	Signal indicating whether or not data is acceptable. With the fall of the STROBE signal, data is accepted and then becomes Active.	22	NC
23	PE	Output	Paper end signal	-	-
24	$\overline{\text{FEED}}$	Input	Paper feed signal	-	-
25	$\overline{\text{ERROR}}$	Output	Error processing signal	-	-
26	$\overline{\text{RESET}}$	Input	Initialize signal	-	-
27	Vcc	Input	+5Vdc circuit power supply	28	VP
29	GND	Input	Power supply GND	30	GND
31				32	
33	VP	Input	+5Vdc printer power supply	34	VP

Note: Be sure to connect all the power-supply terminals (27 to 34.)

2-2. Input/output functions

1. $\overline{\text{STROBE}}$ [input]

Command signal for reading data

At the fall of the signal, data is latched.

2. DATA0 to 7 [Input]

8-bit parallel data signal

3. BUSY [Output]

Signal indicating whether or not data is acceptable.

Note: During paper insertion, $\overline{\text{READY}}$ is established after the $\overline{\text{FEED}}$ OFF though the paper has not completely reached the top. So shake by hand after paper has been fed completely.

4. $\overline{\text{ACK}}$ [Output]

Data input end acknowledge signal. After the signal is output, data is acceptable.

5. Paper end signal (PE) [Output]

When the thermal paper remainder becomes the amount equivalent to 7 lines (about 27 mm) from the top section, the PE terminal is at the "HIGH" level, and LED is ON. At this time, the BUSY output is HIGH.

Note: At paper insertion, data entry performed unloaded (empty) printing when the LED is OFF and paper has not completely reached the top.

6. Paper feed signal ($\overline{\text{FEED}}$) [Input]

The FEED switch is provided at the panel. Paper is fed as long as the switch is pressed during roll paper insertion. However, this signal is ignored during printing or when an input signal data of no less than one character has been received.

At the I/O connector, the $\overline{\text{FEED}}$ is provided. (dedicated to the switch input) When the printer head is in the home position (far right), the "LOW" level signal is confirmed and paper is fed by line. While the switch is ON, paper is fed.

It requires the 100 μs or more duration of the LOW level.

7. Error signal ($\overline{\text{ERROR}}$) [Input]

When an error condition (paper clogging and the like) occurs during printing or paper feeding, output to the printer mechanism is turned OFF.

In addition, the error output is at "LOW" level, and the BUSY output is at the "HIGH" level. Data is not receivable. To reset the error state, enter the RESET signal or turn OFF the power supply once.

8. Reset ($\overline{\text{RESET}}$) [Input]

Like in POWER ON resetting, the printer is initialized.

All the input data is cleared by the LOW level signal, and paper is fed by line.

2-3, Basic operations

1. Turn on the power or enter reset, and then initialize the printer. Perform unloaded feeding by one line to remove recording paper looseness.
2. Enter 8-bit data from the host system by shaking the $\overline{\text{STROBE}}$ and BUSY or $\overline{\text{ACK}}$.
3. The entered 8-bit data is stored in the internal data memory. When data is entered by line or when the <CR>, <LF> code data has been entered, printing is performed.
4. The character is printed by converting an entered data code into a dot pattern with the built-in character generator.

2-4. Data timing

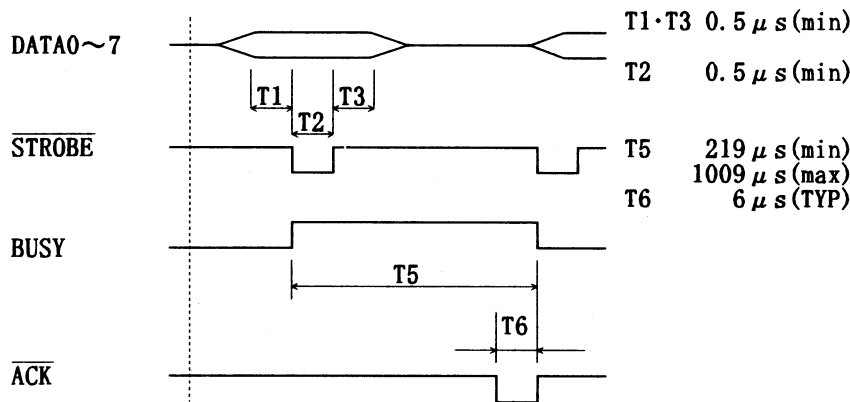

2-5. Electric conditions

• Input signal conditions

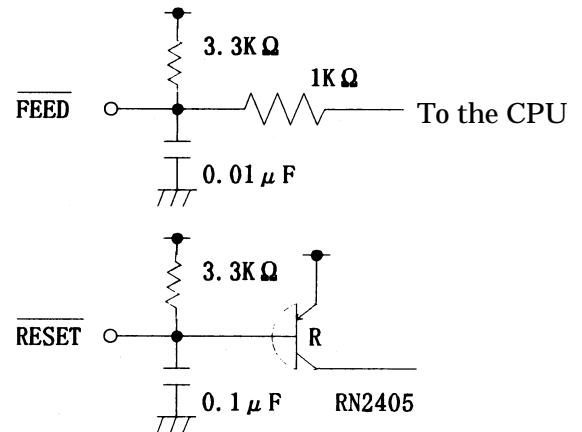
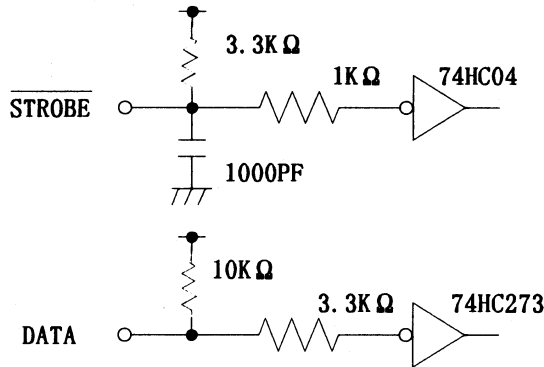

• Output signal conditions

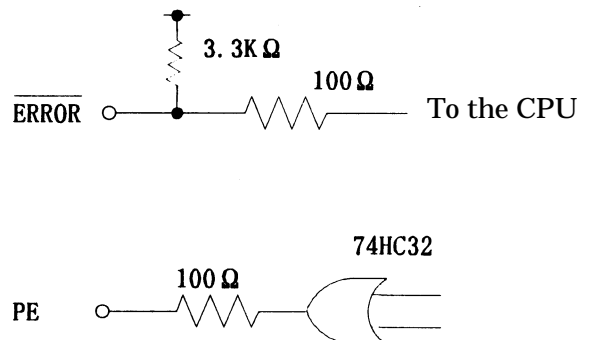
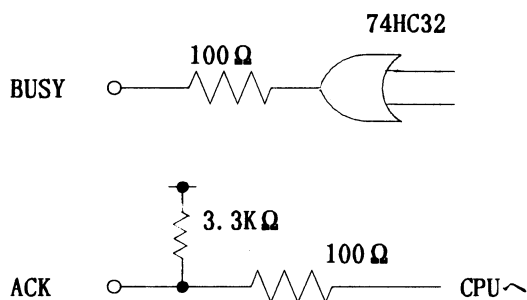

Options (sold separately)

1. Paper

Paper is available in units of 20 rolls.
Model name: P-58-15
Thermal paper black color development

2. Cables

1). PK-1 (cable 1)

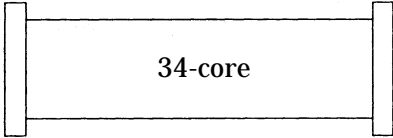

- Connector: HIF3BA-34D-2.54R (Hirose)
- Cable length: 500 mm

2) PK-2 (cable 2)

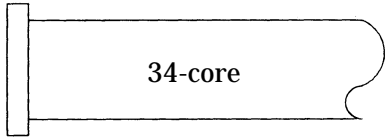

- Connector: HIF3BA-34D-2.54R (Hirose)
- Cable length: 500 mm

3) PK-3 (cable 3)

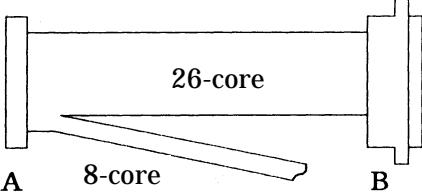

- Connector A: HIF3BA-34D-2.54R (Hirose)
- Connector B: 57F-40360 (DDK) ... Pressure-fit connector for flat cable
- Cable length: 500 mm

For inquiries:

 **SANEI ELECTRIC INC.**

171-0014

Taisou Ikebukuro Building 5F,
2-61-1, Ikebukuro, Toshima-ku, Tokyo, Japan

Phone: +81-3-3986-0646 (representative)

Fax: +81-3-3988-5876

Opens at 9:00 am and closes at 5:00 pm
(except 12:00 to 1:00)

(Closed on Saturday, Sunday and national
holidays.)